

# Brückner Stenters

body dimensions				fill						Gutmann article-nr.
inner ø (di/d2)	outer ø (da)	width (b)	pitch circle Ø (TK)	fill material	trim mm	rows	operating width (B) mm	style		
mm	mm	mm	mm					straight	conv.	
										

## Postpinning Brush Ø 150 mm (D)

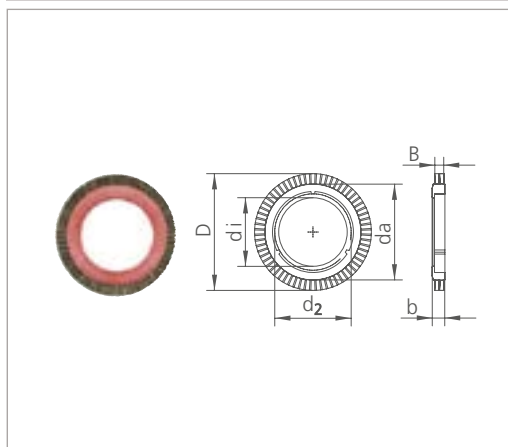

88/98	124.0	16.0		Calcutta bristle grey	13.0	2	11	•		<b>8011-0150-02</b>
88/98	124.0	16.0		Chungking bristle black	13.0	2	10	•		<b>8011-0150-12</b>
88/98	124.0	16.0		horsehair black	13.0	2	12	•		<b>8011-0150-22</b>
88/98	124.0	16.0		PA 6.6 white 0.40 mm	13.0	2	11	•		<b>8011-0150-42</b>
88/98	124.0	16.0		PA 6.6 white 0.70 mm	13.0	2	11	•		<b>8011-0150-72</b>
88/98	124.0	16.0		Calcutta-Borste grau	13.0	2	8		•	<b>8011-1150-02</b>
88/98	124.0	16.0		Chungking bristle black	13.0	2	7		•	<b>8011-1150-12</b>
88/98	124.0	16.0		horsehair black	13.0	2	8		•	<b>8011-1150-22</b>
88/98	124.0	16.0		PA 6.6 white 0.40 mm	13.0	2	7		•	<b>8011-1150-42</b>
88/98	124.0	16.0		PA 6.6 white 0.70 mm	13.0	2	8		•	<b>8011-1150-72</b>

## Postpinning Brush Ø 160 mm (D)

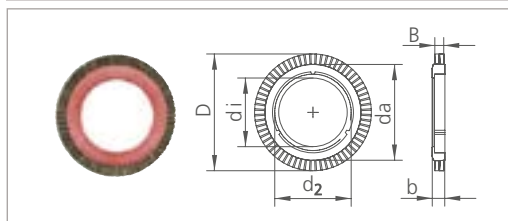

88/98	124.0	16.0		Calcutta bristle grey	18.0	2	7		•	<b>8011-1160-02</b>
88/98	124.0	16.0		PA 6.6 white 0.40 mm	18.0	2	8		•	<b>8011-1160-42</b>

# Brückner Stenters

body dimensions				fill						Gutmann article-nr.
inner ø (di/d2)	outer ø (da)	width (b)	pitch circle Ø (TK)	fill material	trim mm	rows	operating width (B) mm	style		
mm	mm	mm	mm					straight	conv.	
										

## Overfeed Brush Ø 220 mm (D)

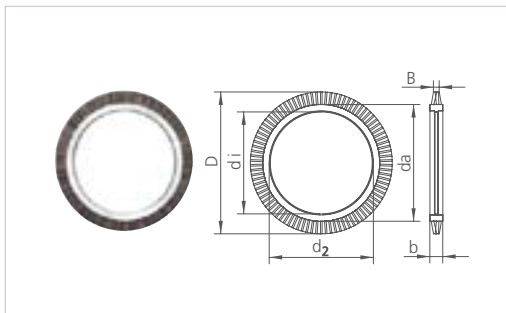

158/161.5	181.0	20.0		Calcutta bristle grey	19.5	4	17	•		8032-0220-04
158/161.5	181.0	20.0		Chungking bristle black	19.5	4	17	•		8032-0220-34
158/161.5	181.0	20.0		Calcutta bristle grey	19.5	4	11		•	8032-1220-04
158/161.5	181.0	20.0		Chungking bristle black	19.5	4	11		•	8032-1220-14
158/161.5	181.0	20.0		horsehair black	19.5	4	13		•	8032-1220-24
158/161.5	181.0	20.0		PA 6.6 white 0.40 mm	19.5	4	11		•	8032-1220-44
158/161.5	181.0	20.0		PA 6.6 white 0.70 mm	19.5	4	12		•	8032-1220-74

## Edge Cutting Brush Ø 85 mm (D)

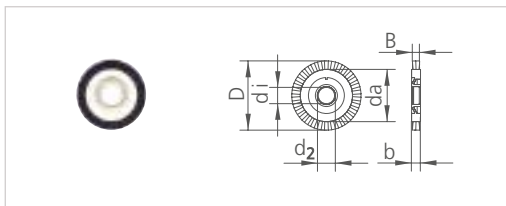

21.95/20	64.0	11.0		horsehair black	10.5	2	9	•		8043-0085-22
----------	------	------	--	-----------------	------	---	---	---	--	--------------

# Brückner Stenters

body dimensions				fill						Gutmann article-nr.
inner ø (di/d2)	outer ø (da)	width (b)	pitch circle Ø (TK)	fill material	trim	rows	operating width (B)	style		
mm	mm	mm	mm					mm	mm	
										

## Universal Brush Ø 201 mm (D)

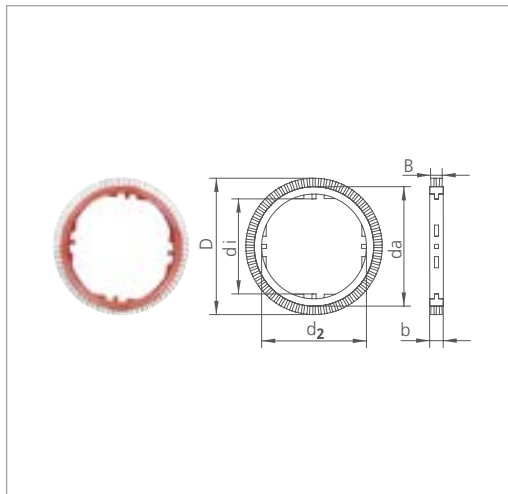

140/154	176.0	20.0		Calcutta bristle grey	12.5	4	17	•		8221-0201-04
140/154	176.0	20.0		Chungking bristle black	12.5	4	17	•		8221-0201-14
140/154	176.0	20.0		horsehair black	12.5	4	17	•		8221-0201-24
140/154	176.0	20.0		PA 6.6 white 0.40 mm	12.5	4	17	•		8221-0201-44
140/1544	176.0	20.0		PA 6.6 white 0.70 mm	12.5	4	18	•		8221-0201-74
140/154	176.0	20.0		stainless steel wire 0.25 mm	12.5	4	20	•		8221-0201-84
140/154	176.0	20.0		Calcutta bristle grey	12.5	3	9		•	8221-1201-03
L140/154	176.0	20.0		Chungking bristle black	12.5	3	11		•	8221-1201-13
140/154	176.0	20.0		horsehair black	12.5	3	10		•	8221-1201-23
140/154	176.0	20.0		PA 6.6 white 0.40 mm	12.5	3	11		•	8221-1201-43
140/154	176.0	20.0		PA 6.6 white 0.70 mm	12.5	3	8		•	8221-1201-73

## Brush for cutting device Ø 85 mm (D) (also check bushings for 8411-....-..)

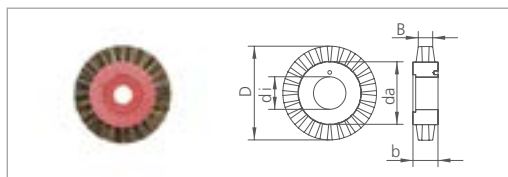

26	50.0	20.0		Calcutta bristle grey	17.5	4	18	•		8411-0085-54
----	------	------	--	-----------------------	------	---	----	---	--	--------------

## Postpinning Brush Ø 75 mm (D) (also check bushings for 8411-....-..)

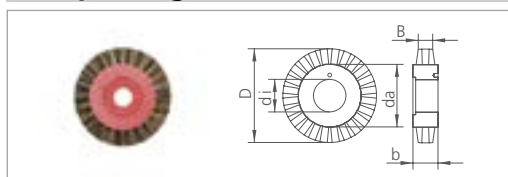

26	50.0	20.0		Calcutta bristle grey	12.5	3	10		•	8411-1075-03
26	50.0	20.0		Chungking bristle black	12.5	3	10		•	8411-1075-13

# Brückner Stenters

body dimensions				fill						Gutmann article-nr.
inner $\varnothing$ (di/d2)	outer $\varnothing$ (da)	width (b)	pitch circle $\varnothing$ (TK)	fill material	trim	rows	operating width (B)	style		
mm	mm	mm	mm					mm	mm	
										

## Universal Brush / Overfeed Brush $\varnothing$ 220 mm (D)

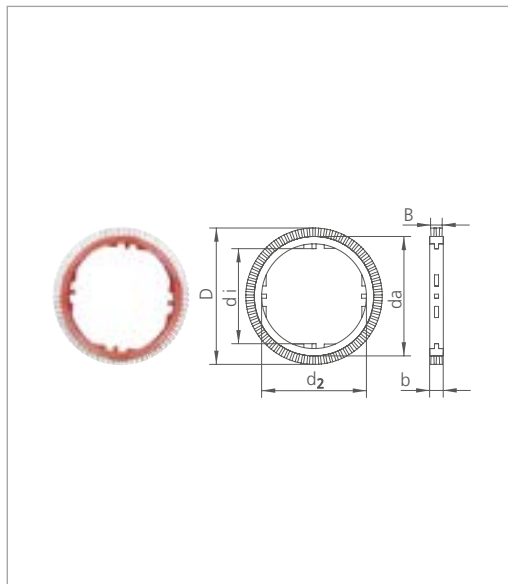

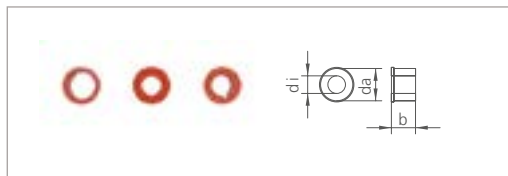

158/167	189.0	20.0		horsehair black	15.5	4	18	•		8231-0220-24
158/167	189.0	20.0		Chungking bristle black	15.5	4	18	•		8231-0220-34
158/167	189.0	20.0		PA 6.6 white 0.40 mm	15.5	4	17	•		8231-0220-44
158/167	189.0	20.0		Calcutta bristle grey	15.5	4	18	•		8231-0220-54
158/167	189.0	20.0		PA 6.6 white 0.70 mm	15.5	4	18	•		8231-0220-74
158/167	189.0	20.0		stainless steel wire 0.25 mm	15.5	4	21	•		8231-0220-84
158/167	189.0	20.0		goat hair white	15.5	4	19	•		8231-0220-Z4
158/167	189.0	20.0		horsehair black	15.5	4	12		•	8231-1220-24
158/167	189.0	20.0		Chungking bristle black	15.5	4	10		•	8231-1220-34
158/167	189.0	20.0		PA 6.6 white 0.40 mm	15.5	4	10		•	8231-1220-44
158/167	189.0	20.0		Calcutta bristle grey	15.5	4	10		•	8231-1220-54
158/167	189.0	20.0		PA 6.6 white 0.70 mm	15.5	4	11		•	8231-1220-74
158/167	189.0	20.0		stainless steel wire 0.25 mm	15.5	4	11		•	8231-1220-84

## Bushings for 8411-....-.. (50-8412 with key slot (for cutting device))



14	26	19.5								50-8411
15	26	19.5								50-8412

# Brückner Stenters

body dimensions				fill						Gutmann article-nr.
inner ø (di/d2)	outer ø (da)	width (b)	pitch circle Ø (TK)	fill material	trim mm	rows	operating width (B) mm	style		
mm	mm	mm	mm					straight	conv.	
										

## Brush Ring Ø 120 mm (D)

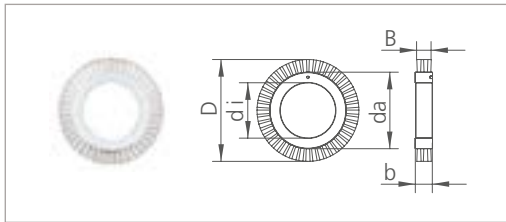

65	90.0	20.0		PA 6.6 white 0.40 mm	15.0	4		•		<b>8699-0120-44</b>
----	------	------	--	----------------------	------	---	--	---	--	---------------------

## Clip Cleaning Brush Ø 220 mm (D)

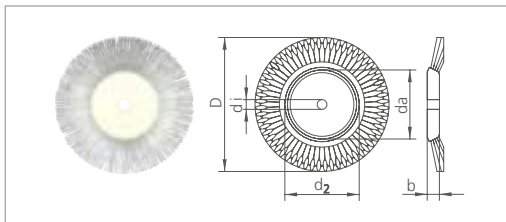

16	122.0	20.0		PA 6.6 white 0.70 mm	54.0/59	4				<b>89-2324-4</b>
16	122.0	20.0		crimped brass wire 0.40 mm	54.0/59	4				<b>89-2324-9</b>

## Clip Opener made of thermoset 52 x 70 mm

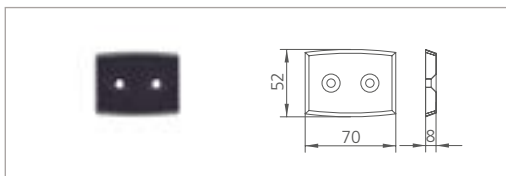

										<b>50-3324</b>
--	--	--	--	--	--	--	--	--	--	----------------

We offer the world's most extensive product portfolios of stenter brushes.  
If, contrary to expectations, none of them fits your requirements,  
please ask us to for an individual production of your stenter brush.