



# Monforts, Montex Spannrahmen

Körpermaße				Besatz						Gutmann Art.-Nr.
Innen ø (di/d2)	Außen ø (da)	Breite (b)	Teilkreis (TK)	Besatzmaterial	Borsten- länge	Anzahl Reihen	Arbeits- breite (ca.) (B) mm	Besatzstellung		
mm	mm	mm	mm		mm			gerade 	konisch 	

## Aufnadelbürste Ø 220 mm (D)



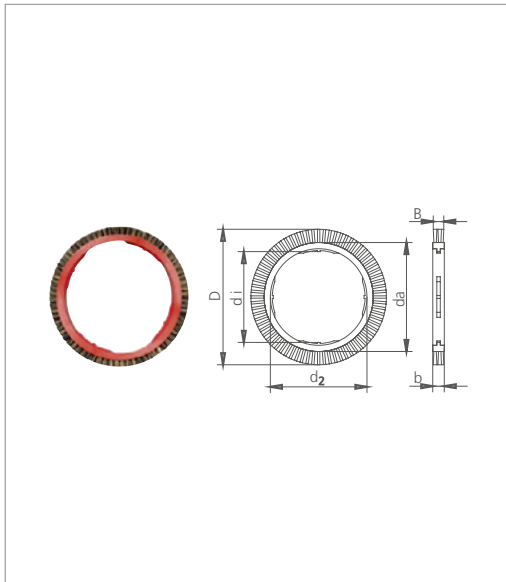

158/167	189,0	20,0		Rosshaar schwarz	15,5	4	18	•		8231-0220-24
158/167	189,0	20,0		Chungking-Borste schwarz	15,5	4	18	•		8231-0220-34
158/167	189,0	20,0		PA 6.6 weiß 0,40 mm	15,5	4	17	•		8231-0220-44
158/167	189,0	20,0		Calkutta-Borste grau	15,5	4	18	•		8231-0220-54
158/167	189,0	20,0		PP weiß 0,40 mm	15,5	4	17	•		8231-0220-64
158/167	189,0	20,0		PA 6.6 weiß 0,70 mm	15,5	4	18	•		8231-0220-74
158/167	189,0	20,0		V2A-Draht glatt 0,25 mm	15,5	4	21	•		8231-0220-84
158/167	189,0	20,0		Rosshaar schwarz	15,5	4	12		•	8231-1220-24
158/167	189,0	20,0		Chungking-Borste schwarz	15,5	4	10		•	8231-1220-34
158/167	189,0	20,0		PA 6.6 weiß 0,40 mm	15,5	4	10		•	8231-1220-44
158/167	189,0	20,0		Calkutta-Borste grau	15,5	4	10		•	8231-1220-54
158/167	189,0	20,0		PA 6.6 weiß 0,70 mm	15,5	4	11		•	8231-1220-74
158/167	189,0	20,0		V2A-Draht glatt 0,25 mm	15,5	4	11		•	8231-1220-84

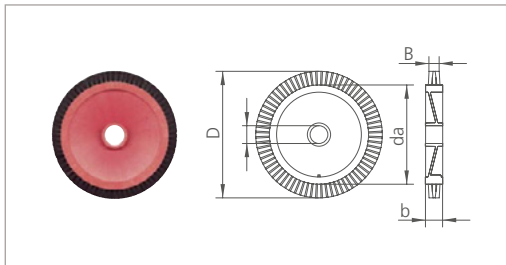
## Nachnadelbürste Ø 175 mm (D) (inkl. Reduzierhülse 50-8562)



26	145,0	25,0		Calkutta-Borste grau	15,0	3	16		•	8571-1175-03
26	145,0	25,0		Chungking-Borste schwarz	15,0	3	14		•	8571-1175-13
26	145,0	25,0		Rosshaar schwarz	15,0	3	15		•	8571-1175-23
26	145,0	25,0		PA 6.6 weiß 0,40 mm	15,0	3	13		•	8571-1175-43
26	145,0	25,0		PA 6.6 weiß 0,70 mm	15,0	3	14		•	8571-1175-73
26	145,0	25,0		V2A-Draht glatt 0,25 mm	15,0	3	14		•	8571-1175-83

# Monforts, Montex Spannrahmen

Körpermaße				Besatz						Gutmann	
Innen ø (di/d2)	Außen ø (da)	Breite (b)	Teilkreis (TK)	Besatzmaterial	Borstenlänge	Anzahl Reihen	Arbeitsbreite (ca.) (B) mm	Besatzstellung		Art.-Nr.	
mm	mm	mm	mm		mm			gerade 	konisch 		

## Nachnadelbürste Ø 185 mm (D) (inkl. Reduzierhülse 50-8562)

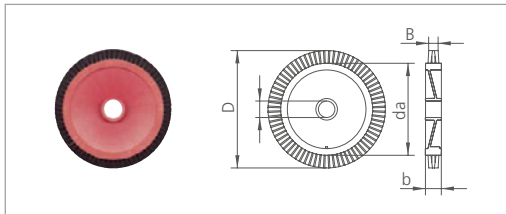

26	145,0	25,0		Rosshaar schwarz	20,0	3	15		•	8571-1185-23
26	145,0	25,0		PA 6.6 weiß 0,40 mm	20,0	3	12		•	8571-1185-43

## Reduzierhülse



22	26,0	25,0								50-8562
----	------	------	--	--	--	--	--	--	--	---------

## Kantenschneidbürste Ø 60 mm (D)

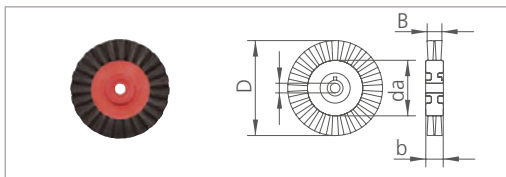

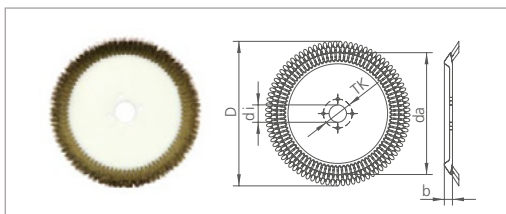

6,2	35,0	11,0		Rosshaar schwarz	12,5	2	10		•	69-2326-H-1
-----	------	------	--	------------------	------	---	----	--	---	-------------

## Kluppenreinigungsbürste Ø 250 mm (D)



30	210,0	14,0	50,0	V2A-Draht gew. 0,20 mm	11	2				82-2330-8
30	210,0	14,0	50,0	Messingdraht gew. 0,20 mm	11	2				82-2330-9

# Monforts, Montex Spannrahmen

Körpermaße				Besatz						Gutmann	
Innen ø (di/d2)	Außen ø (da)	Breite (b)	Teilkreis (TK)	Besatzmaterial	Borsten- länge	Anzahl Reihen	Arbeits- breite (ca.) (B) mm	Besatzstellung		Art.-Nr.	
mm	mm	mm	mm		mm			gerade 	konisch 		

## Nadelleistenreinigungsbürste Ø 185 mm (D)

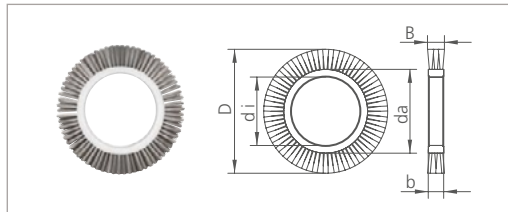

102	125,0	23,0		V2A-Draht glatt 0,30 mm	30,0	5	24	•		<b>8475-0185-85</b>
-----	-------	------	--	-------------------------	------	---	----	---	--	---------------------

Wir bieten das weltweit größte Programm an Spannrahmenbürsten.  
Sollte wider Erwarten keine für Ihre Anforderung passen, fragen Sie uns  
nach einer individuellen Fertigung Ihrer Spannrahmenbürste.