

Brückner Spannrahmen

Körpermaße				Besatz						Gutmann Art.-Nr.
Innen \varnothing (di/d2)	Außen \varnothing (da)	Breite (b)	Teilkreis (TK)	Besatzmaterial	Borsten- länge	Anzahl Reihen	Arbeits- breite (ca.) (B) mm	Besatzstellung		
mm	mm	mm	mm		mm			gerade 	konisch 	

Nachnadelbürste \varnothing 150 mm (D)

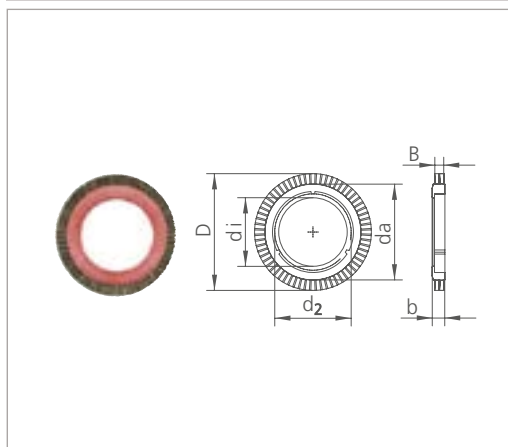

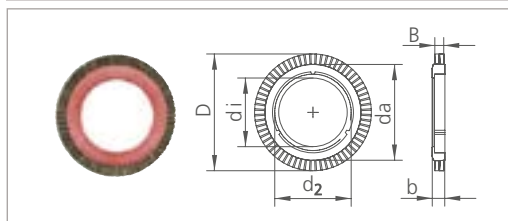

88/98	124,0	16,0		Calkutta-Borste grau	13,0	2	11	•		8011-0150-02
88/98	124,0	16,0		Chungking-Borste schwarz	13,0	2	10	•		8011-0150-12
88/98	124,0	16,0		Rosshaar schwarz	13,0	2	12	•		8011-0150-22
88/98	124,0	16,0		PA 6.6 weiß 0,40 mm	13,0	2	11	•		8011-0150-42
88/98	124,0	16,0		PA 6.6 weiß 0,70 mm	13,0	2	11	•		8011-0150-72
88/98	124,0	16,0		Calkutta-Borste grau	13,0	2	8		•	8011-1150-02
88/98	124,0	16,0		Chungking-Borste schwarz	13,0	2	7		•	8011-1150-12
88/98	124,0	16,0		Rosshaar schwarz	13,0	2	8		•	8011-1150-22
88/98	124,0	16,0		PA 6.6 weiß 0,40 mm	13,0	2	7		•	8011-1150-42
88/98	124,0	16,0		PA 6.6 weiß 0,70 mm	13,0	2	8		•	8011-1150-72

Aufnadelbürste \varnothing 160 mm (D)



88/98	124,0	16,0		Calkutta-Borste grau	18,0	2	7		•	8011-1160-02
88/98	124,0	16,0		PA 6.6 weiß 0,40 mm	18,0	2	8		•	8011-1160-42

Brückner Spannrahmen

Körpermaße				Besatz						Gutmann	
Innen ø (di/d2)	Außen ø (da)	Breite (b)	Teilkreis (TK)	Besatzmaterial	Borsten- länge	Anzahl Reihen	Arbeits- breite (ca.) (B) mm	Besatzstellung		Art.-Nr.	
mm	mm	mm	mm		mm			gerade 	konisch 		

Aufnadelbürste Ø 220 mm

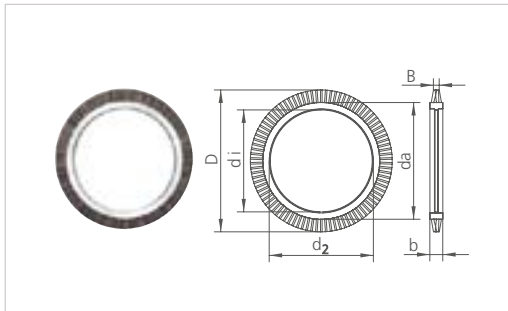

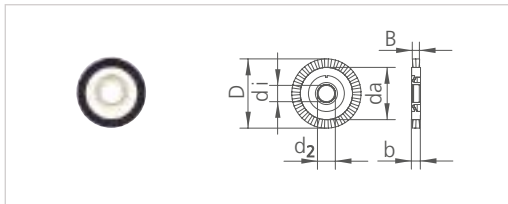

158/161,5	181,0	20,0		Calkutta-Borste grau	19,5	4	17	•		8032-0220-04
158/161,5	181,0	20,0		Chungking-Borste schwarz	19,5	4	17	•		8032-0220-34
158/161,5	181,0	20,0		Calkutta-Borste grau	19,5	4	11		•	8032-1220-04
L158/161,5	181,0	20,0		Chungking-Borste schwarz	19,5	4	11		•	8032-1220-14
158/161,5	181,0	20,0		Rosshaar schwarz	19,5	4	13		•	8032-1220-24
158/161,5	181,0	20,0		PA 6.6 weiß 0,40 mm	19,5	4	11		•	8032-1220-44
L158/161,5	181,0	20,0		PA 6.6 weiß 0,70 mm	19,5	4	12		•	8032-1220-74

Kantenschneidbürste Ø 85 mm



21,95/20	64,0	11,0		Rosshaar schwarz	10,5	2	9	•		8043-0085-22
----------	------	------	--	------------------	------	---	---	---	--	--------------

Brückner Spannrahmen

Körpermaße				Besatz						Gutmann Art.-Nr.
Innen \varnothing (d_i/d_2)	Außen \varnothing (d_a)	Breite (b)	Teilkreis (TK)	Besatzmaterial	Borsten- länge	Anzahl Reihen	Arbeits- breite (ca.) (B) mm	Besatzstellung		
mm	mm	mm	mm		mm			gerade 	konisch 	

Universal Bürste \varnothing 201 mm (D)

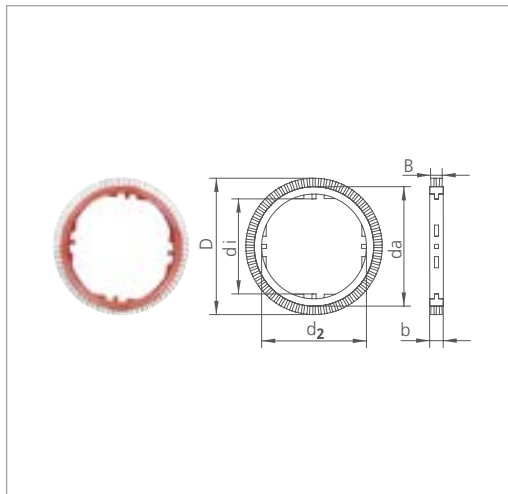

140/154	176,0	20,0		Calkutta-Borste grau	12,5	4	17	•		8221-0201-04
140/154	176,0	20,0		Chungking-Borste schwarz	12,5	4	17	•		8221-0201-14
140/154	176,0	20,0		Rosshaar schwarz	12,5	4	17	•		8221-0201-24
140/154	176,0	20,0		PA 6.6 weiß 0,40 mm	12,5	4	17	•		8221-0201-44
140/1544	176,0	20,0		PA 6.6 weiß 0,70 mm	12,5	4	18	•		8221-0201-74
140/154	176,0	20,0		V2A-Draht glatt 0,25 mm	12,5	4	20	•		8221-0201-84
140/154	176,0	20,0		Calkutta-Borste grau	12,5	3	9		•	8221-1201-03
L140/154	176,0	20,0		Chungking-Borste schwarz	12,5	3	11		•	8221-1201-13
140/154	176,0	20,0		Rosshaar schwarz	12,5	3	10		•	8221-1201-23
140/154	176,0	20,0		PA 6.6 weiß 0,40 mm	12,5	3	11		•	8221-1201-43
140/154	176,0	20,0		PA 6.6 weiß 0,70 mm	12,5	3	8		•	8221-1201-73

Bürste für Schneideinrichtung \varnothing 85 mm (D) (siehe auch Buchsen zu 8411-....-..)

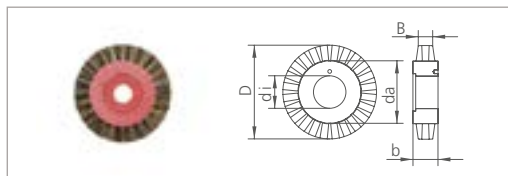

26	50,0	20,0		Calkutta-Borste grau	17,5	4	18	•		8411-0085-54
----	------	------	--	----------------------	------	---	----	---	--	---------------------

Nachnadelbürste \varnothing 75 mm (D) (siehe auch Buchsen zu 8411-....-..)

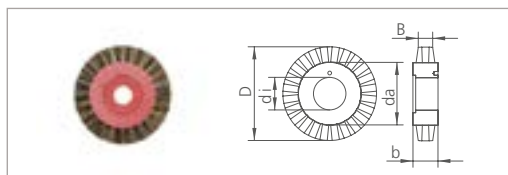

26	50,0	20,0		Calkutta-Borste grau	12,5	3	10		•	8411-1075-03
26	50,0	20,0		Chungking-Borste schwarz	12,5	3	10		•	8411-1075-13

Brückner Spannrahmen

Körpermaße				Besatz						Gutmann Art.-Nr.
Innen ø (di/d2)	Außen ø (da)	Breite (b)	Teilkreis (TK)	Besatzmaterial	Borsten- länge	Anzahl Reihen	Arbeits- breite (ca.) (B) mm	Besatzstellung		
mm	mm	mm	mm		mm			gerade 	konisch 	

Universalbürste / Aufnadelbürste Ø 220 mm (D)

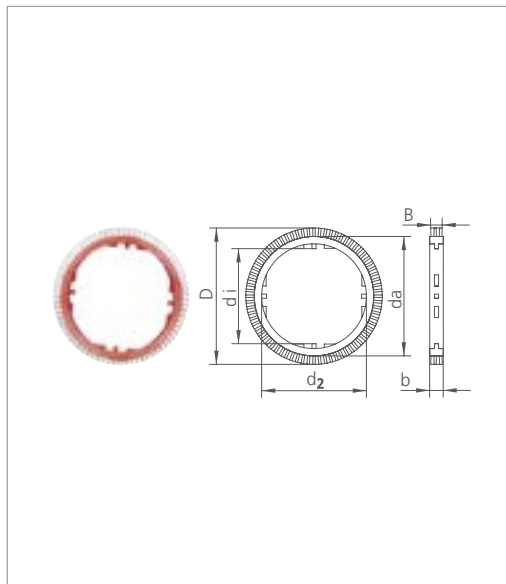

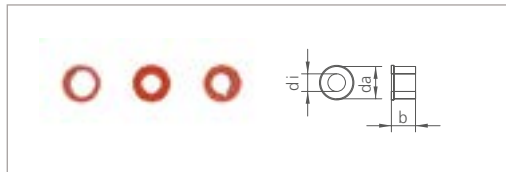

158/167	189,0	20,0		Rosshaar schwarz	15,5	4	18	•		8231-0220-24
158/167	189,0	20,0		Chungking-Borste schwarz	15,5	4	18	•		8231-0220-34
158/167	189,0	20,0		PA 6.6 weiß 0,40 mm	15,5	4	17	•		8231-0220-44
158/167	189,0	20,0		Calkutta-Borste grau	15,5	4	18	•		8231-0220-54
158/167	189,0	20,0		PA 6.6 weiß 0,70 mm	15,5	4	18	•		8231-0220-74
158/167	189,0	20,0		V2A-Draht glatt 0,25 mm	15,5	4	21	•		8231-0220-84
158/167	189,0	20,0		Ziegenhaar weiß	15,5	4	19	•		8231-0220-Z4
158/167	189,0	20,0		Rosshaar schwarz	15,5	4	12		•	8231-1220-24
158/167	189,0	20,0		Chungking-Borste schwarz	15,5	4	10		•	8231-1220-34
158/167	189,0	20,0		PA 6.6 weiß 0,40 mm	15,5	4	10		•	8231-1220-44
158/167	189,0	20,0		Calkutta-Borste grau	15,5	4	10		•	8231-1220-54
158/167	189,0	20,0		PA 6.6 weiß 0,70 mm	15,5	4	11		•	8231-1220-74
158/167	189,0	20,0		V2A-Draht glatt 0,25 mm	15,5	4	11		•	8231-1220-84

Buchsen zu 8411-....-.. (50-8412 mit Keilnut-Schneideeinrichtung)



14	26	19,5								50-8411
15	26	19,5								50-8412

Brückner Spannrahmen

Körpermaße				Besatz						Gutmann	
Innen ø (di/d2)	Außen ø (da)	Breite (b)	Teilkreis (TK)	Besatzmaterial	Borstenlänge	Anzahl Reihen	Arbeitsbreite (ca.) (B) mm	Besatzstellung		Art.-Nr.	
mm	mm	mm	mm		mm			gerade 	konisch 		

Bürstenring Ø 120 mm (D)

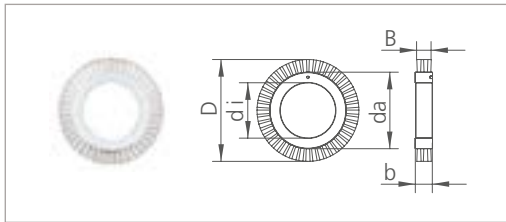

65	90,0	20,0		PA 6.6 weiß 0,40 mm	15,0	4		•		8699-0120-44
----	------	------	--	---------------------	------	---	--	---	--	---------------------

Kluppenreinigungsbürste Ø 220 mm (D)

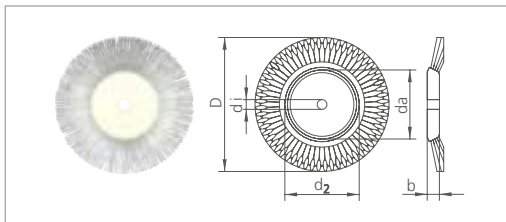

16	122,0	20,0		PA 6.6 weiß 0,70 mm	54,0/59	4				89-2324-4
16	122,0	20,0		Messing gew. 0,40 mm	54,0/59	4				89-2324-9

Öffnersegment aus Duroplast 52 x 70 mm

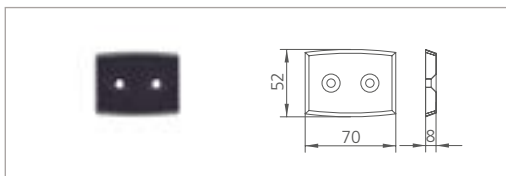

										50-3324
--	--	--	--	--	--	--	--	--	--	----------------

Wir bieten das weltweit größte Programm an Spannrahmenbürsten.
Sollte wider Erwarten keine für Ihre Anforderung passen, fragen Sie uns
nach einer individuellen Fertigung Ihrer Spannrahmenbürste.