

Artos Spannrahmen

Körpermaße				Besatz						Gutmann	
Innen ø (di/d2)	Außen ø (da)	Breite (b)	Teilkreis (TK)	Besatzmaterial	Borsten- länge	Anzahl Reihen	Arbeits- breite (ca.) (B) mm	Besatzstellung		Art.-Nr.	
mm	mm	mm	mm		mm			gerade 	konisch 		

Nachadelbürste Ø 180 mm (D)

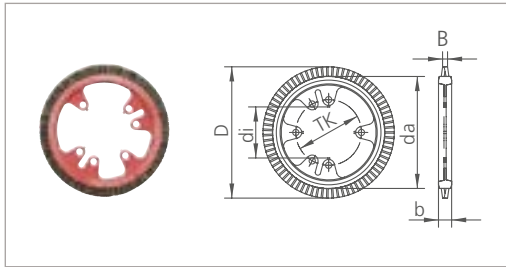

70	154,0	18,0	90,0	Calkutta-Borste grau	13,0	2	8		•	8111-1180-02
70	154,0	18,0	90,0	Chungking-Borste schwarz	13,0	2	7		•	8111-1180-12
70	154,0	18,0	90,0	Rosshaar schwarz	13,0	2	11		•	8111-1180-22
70	154,0	18,0	90,0	PA 6.6 weiß 0,40 mm	13,0	2	7		•	8111-1180-42
70	154,0	18,0	90,0	PA 6.6 weiß 0,70 mm	13,0	2	8		•	8111-1180-72
70	154,0	18,0	90,0	V2A-Draht glatt 0,25 mm	13,0	2	11		•	8111-1180-82

Aufnadelbürste Ø 200 mm (D)

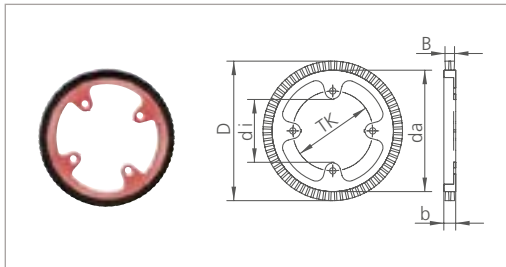

90	174,0	17,0	114,5	Calkutta-Borste grau	13,0	3	14		•	8121-0200-03
90	174,0	17,0	114,5	Chungking-Borste schwarz	13,0	3	14		•	8121-0200-13
90	174,0	17,0	114,5	Rosshaar schwarz	13,0	3	14		•	8121-0200-23
90	174,0	17,0	114,5	PA 6.6 weiß 0,40 mm	13,0	3	14		•	8121-0200-43

Nachadelbürste Ø 206 mm (D) (für Bj. 1988 bis 1991)

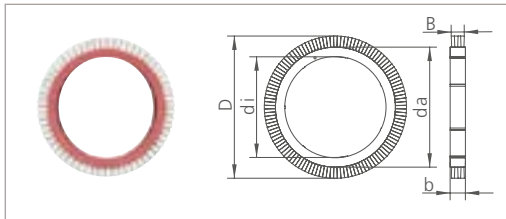

145,1	173,0	22,0	P	PA 6.6 weiß 0,40	16,5	3	16		•	8331-1206-43
-------	-------	------	---	------------------	------	---	----	--	---	---------------------

Artos Spannrahmen

Körpermaße				Besatz						Gutmann Art.-Nr.
Innen \varnothing (di/d2)	Außen \varnothing (da)	Breite (b)	Teilkreis (TK)	Besatzmaterial	Borsten- länge	Anzahl Reihen	Arbeits- breite (ca.) (B) mm	Besatzstellung		
mm	mm	mm	mm		mm			gerade 	konisch 	

Auf- und Nachnadelbürste \varnothing 206 mm (D)

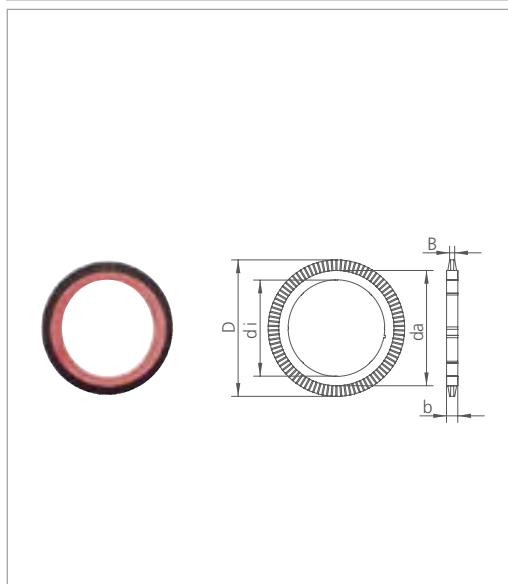

145	174,0	17,0		Rosshaar schwarz	16,0	3	15	•		8511-0206-23
145	174,0	17,0		Chungking-Borste schwarz	16,0	3	14	•		8511-0206-33
145	174,0	17,0		PA 6.6 weiß 0,40 mm	16,0	3	15	•		8511-0206-43
145	174,0	17,0		Calkutta-Borste grau	16,0	3	15	•		8511-0206-53
145	174,0	17,0		PA 6.6 weiß 0,70 mm	16,0	3	14	•		8511-0206-73
145	174,0	17,0		V2A-Draht glatt 0,25 mm	16,0	3	14	•		8511-0206-83
145	174,0	17,0		Rosshaar schwarz	16,0	3	10		•	8511-1206-23
145	174,0	17,0		Chungking-Borste schwarz	16,0	3	9		•	8511-1206-33
145	174,0	17,0		PA 6.6 weiß 0,40 mm	16,0	3	9		•	8511-1206-43
145	174,0	17,0		Calkutta-Borste grau	16,0	3	8		•	8511-1206-53
145	174,0	17,0		PA 6.6 weiß 0,70 mm	16,0	3	10		•	8511-1206-73
145	174,0	17,0		Ziegenhaar weiß	16,0	3	11		•	8511-1206-93
145	174,0	17,0		PA 6.12 schwarz 0,50 mm	16,0	3	8		•	8511-1206-X3

Auf- und Nachnadelbürste \varnothing 211 mm (D)

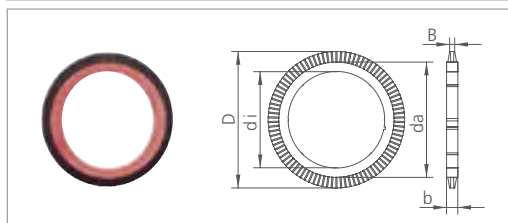

145	174,0	17,0		Calkutta-Borste grau	18,5	3	16	•		8511-0211-53
-----	-------	------	--	----------------------	------	---	----	---	--	--------------

Artos Spannrahmen

Körpermaße				Besatz						Gutmann	
Innen ø (di/d2)	Außen ø (da)	Breite (b)	Teilkreis (TK)	Besatzmaterial	Borsten- länge	Anzahl Reihen	Arbeits- breite (ca.) (B) mm	Besatzstellung		Art.-Nr.	
mm	mm	mm	mm		mm			gerade 	konisch 		

Kantenschneidbürste Ø 60 mm (D)

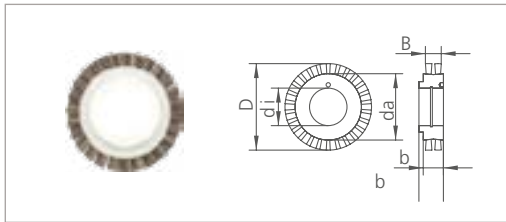

26	46,0	14 /17		Chungking-Borste schwarz	7,0	2	10	•		8555-0060-12
----	------	--------	--	--------------------------	-----	---	----	---	--	---------------------

Nadelleistenreinigungsbürste

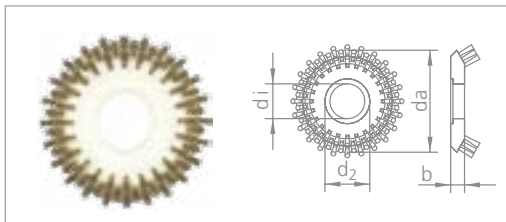

45/58	132,0	18,0		PA 6.6 weiß 0,40 mm	20,0	3				82-2322-4
45/58	132,0	18,0		V2A-Draht glatt 0,25 mm	20,0	3				82-2322-8
45/58	132,0	18,0		V2A-Draht gew. 0,30 mm	20,0	3				82-2322-9
45/58	132,0	18,0		Messingdraht gew. 0,30 mm	20,0	3				82-2322-10

Kluppenreinigungsbürste Ø 210/175 mm (D)

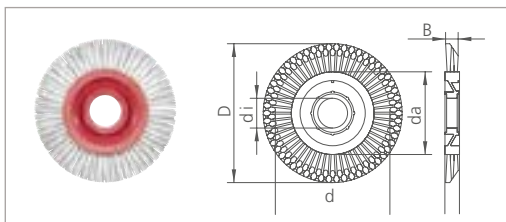

45	125,0	22,0		PA 6.6 weiß 0,70 mm	42,5	3	18			8541-4210-73
45	125,0	22,0		V2A-Draht gew. 0,30 mm	42,5	3	20			8541-4210-83
45	125,0	22,0		Messing gew. 0,30 mm	42,5	3	24			8541-4210-93

Wir bieten das weltweit größte Programm an Spannrahmenbürsten.
Sollte wider Erwarten keine für Ihre Anforderung passen, fragen Sie uns
nach einer individuellen Fertigung Ihrer Spannrahmenbürste.